



Simulation of the Bit Error Rate in UMTS Downlink during Soft Handover

Fernando Soler David
Communications Laboratory

Teacher: Sven-Gustav Häggman
Instructor: Kalle Ruttik



Index

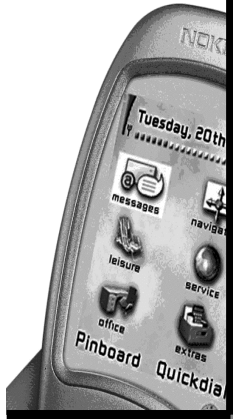

- Introduction
- Background
- Objectives
- Simulation Model
- Simulation Results
- Conclusions



Introduction (I): Properties of a WCDMA system



- Low power spectral density
- Low probability of interception
- Random access possibilities
- Multiple access capability
- Privacy due to unknown random codes
- Reduction of multipath effects
- The main parameter in spread spectrum systems is the processing gain:

$$G_p = \frac{W}{R_j}$$



Introduction (II)

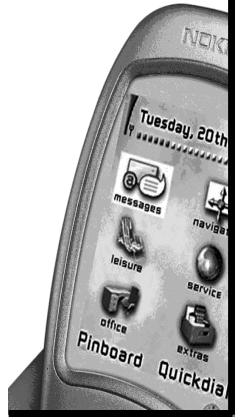

- **Interference** is the main limiting factor in WCDMA system. E_b/N_o is an important parameter of the link quality:

$$\left(\frac{E_b}{N_o} \right) = \frac{W}{R_j} * \frac{P_j}{I_{total} - P_j}$$

- There are several techniques to increase the capacity of the system:
 - Increase the useful signal (P_j) \Rightarrow **Soft Handover (SHO)**
 - Decrease the interfering signal (I)
- SHO is the mechanism that transfer an ongoing call from one cell to another.
- The study of downlink is more important than uplink (more interferences).
- For UMTS system parameters get a complexity which can hardly be dealt with by analytical approaches \Rightarrow computer simulations

Introduction (III): Soft Handover



- The reasons that can activate the execution of a transfer are several:
 - To counteract the deterioration of the connection quality.
 - To reduce transmitted power and to optimise the administration of resources.
 - To define the cell area coverage
 - To redistribute the traffic among cells to avoid congestion and to increase the degree of service.
 - To consent to certain services that can be offered under different operation modes (TDD, FDD).
- Concept of Active Set
 - Msh
 - Combination MRC
(Maximum Ratio Combining)

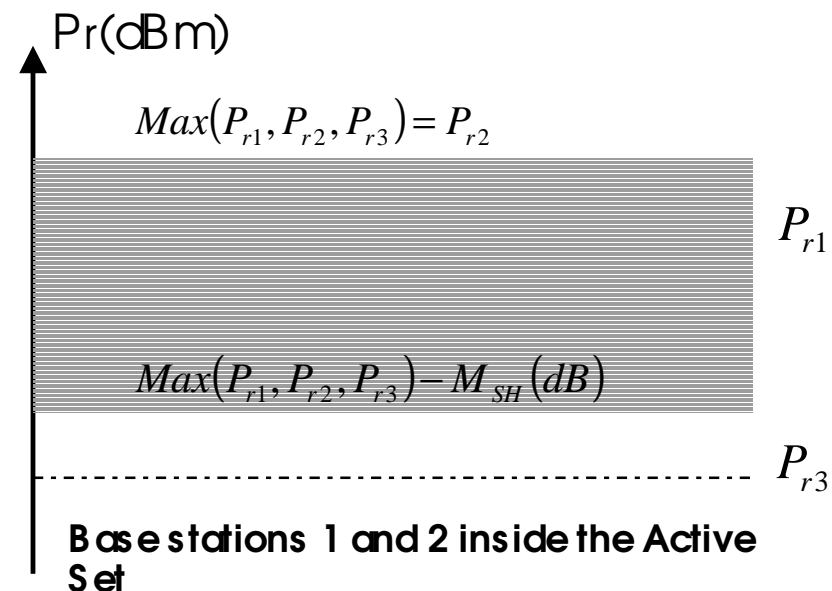



Introduction (IV): Soft Handover



• Advantages

- Reduction of the party effect (inaccuracy of the power control in CDMA systems).
- Reduction of the ping-pong effect (unnecessary handover of the channel)
- Continuity of the service in the physical layer for a moment over the interface.
- Fewer time constraints on the network.
- Soft Handover Gain, reduction of the transmitted power

• Disadvantages

- Additional network resources are used during a soft handoff.
- Soft handover is more complex.
- Downlink interference (to other users) increases when soft handoff is in progress.

Background (I): Previous studies of the downlink soft handover



- In [1] a comparison SIR between SHO with handover margin as parameter and hard handover is done in downlink. The BSs in the active set is two.

Parameters of the simulation:

- SF=128
- 3-ray channel ($\alpha=0.06$)
- activity factor 0.5
- path loss slope ($\mu=3$)
- shadowing ($\sigma = 8\text{dB}$)
- no power control

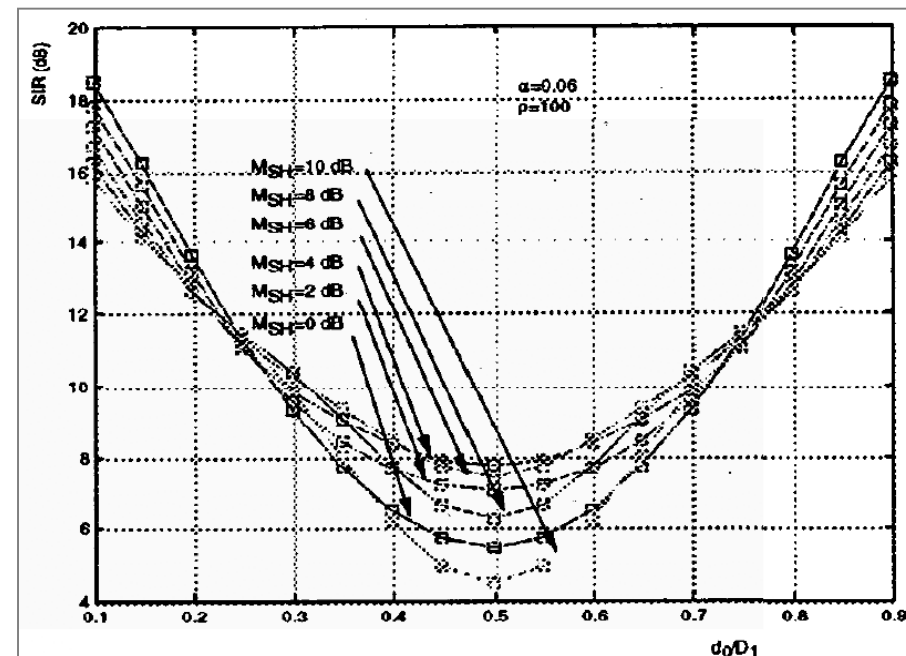

- For users near the cell there is a macrodiversity gain.
- There is an optimal SHO gain in function of received SIR.
- For high Msh (in this case 10 dB) the SHO gain is negative.

Background (II)



- In [2] It analyses the optimum M_{SH} that maximizes the capacity of the system. This parameter depends on the shadowing, users services, required E_b/N_0 , noise, etc.. The number of base stations considers in the active set is 3.

Parameters of the simulation:

- speech users (12,2 kb/s)
- orthogonality factor ($\alpha=0.5$)
- cell size 400 meters
- path loss slope ($\mu=3.5$)
- shadowing ($\sigma = 8\text{dB}$)
- power control

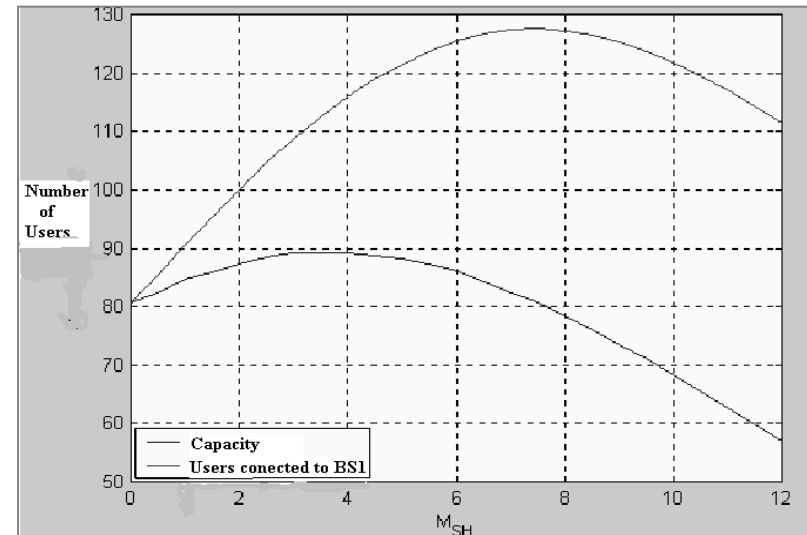

- There is an optimum M_{SH} for each curve that maximizes the capacity.
- The connected users curve represents the total of users that the BS_1 transmits signal to.
- The capacity curve represents the number of users in the system served by BS.



Objetives



- The previous studies has showed the importance of a good knowledge of the downlink soft handover to obtain an increase of the capacity.
- They didn't take in count the number of rake fingers at the receiver.
- The idea is to characterize the system in downlink soft-handover playing with the number of rake fingers running simulations.
- Signal strength estimation from BS is made by using all Rake fingers.
- The BER curves and the soft-handover gain will be calculated in different multipath channel profiles and different soft handover margins.
- These results will depend on the multipath profile, mobile speed, receiver algorithms and control power.
- These results will be useful to review the results of the mentioned researches because they use a fixed number of fingers. They will be able to be used in a radio network planning and dimensioning.

Simulation model (I)

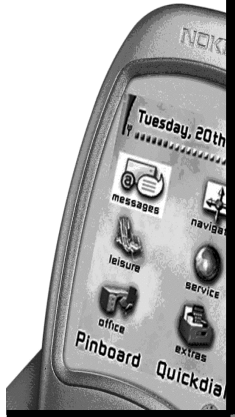

- The number of base stations in the active set is 2.
- The number of users per cell is 15.
- Not coding and interleaving is considered in the simulation \Rightarrow (high computational time)
- It is supposed the same multipath channel profile from both BSs to the MS in situation of soft handover. Three kinds of environments are considered (vehicular, pedestrian, indoor) following recommendation of ETSI.
- The Msh is the average level power between both channels. If the Msh is changed, the taps of one channel are modified according to this value.
- An ideal rake receiver is considered. The delays of the taps are known. MRC is used and the CPICH is used for the estimation of the channel.
- Fast close loop power control is used.
- BER is calculated comparing the original signal with the received signal.
- Soft handover gain is calculated at the $BER = 1e-3$ as the difference of transmitted power between the case in soft handover and not.

Simulation Model(II): System chain

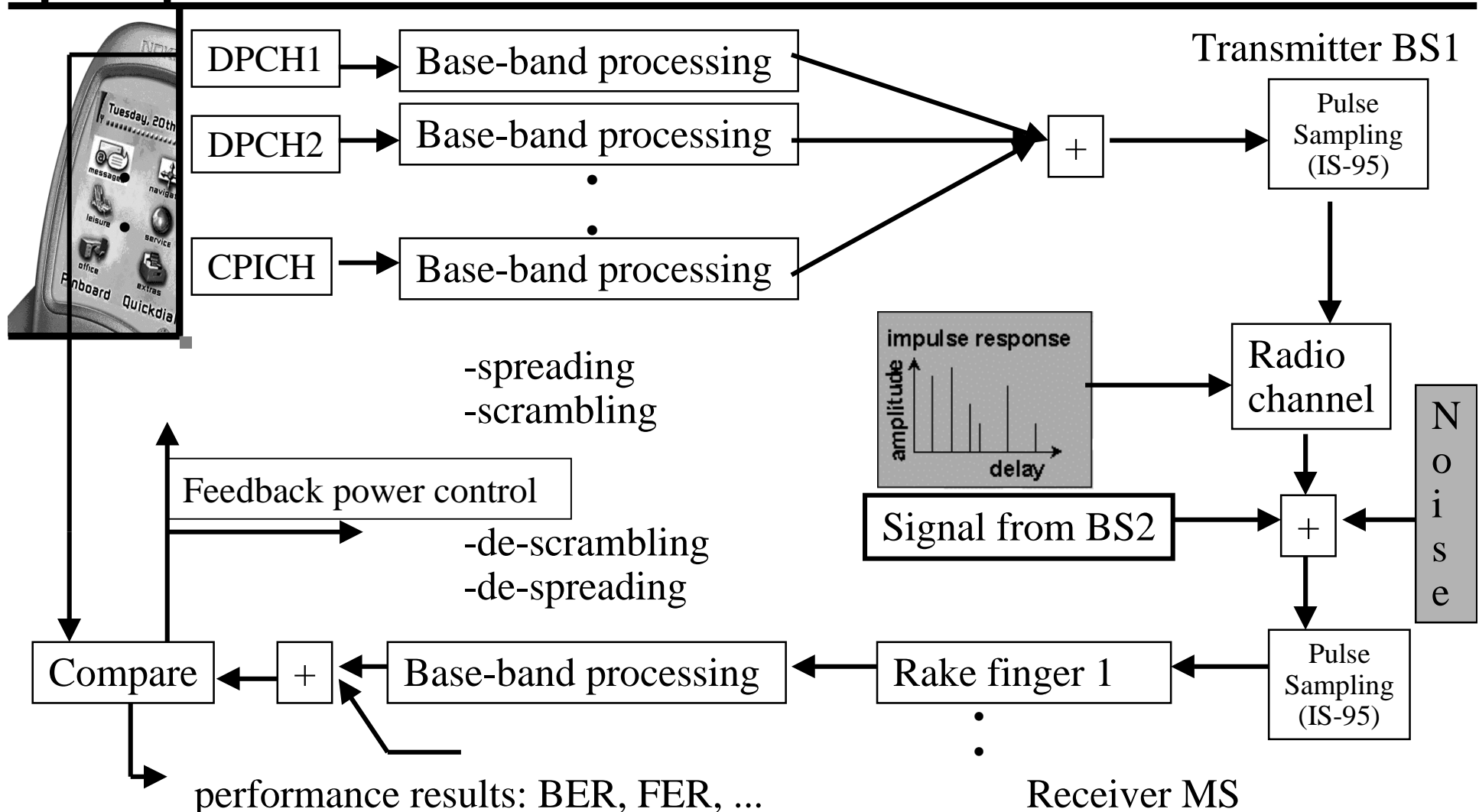

Simulation model (III): Downlink Spreading and Modulation



- **Spreading codes or channelisation** that carry out a first enlarged on the information signal. These codes are orthogonals. They allow to discriminate against the information contained in oneself spectral band starting from this spreading sequence.
- **Scrambling codes** that are applied on the spread signal previously, a process that doesn't suppose any spreading on the signal, maintaining its bandwidth. These codes are not perfectly orthogonal to each other, although they have good autocorrelation properties and their use is especially interesting to be able to distinguish signals coming from different sources.

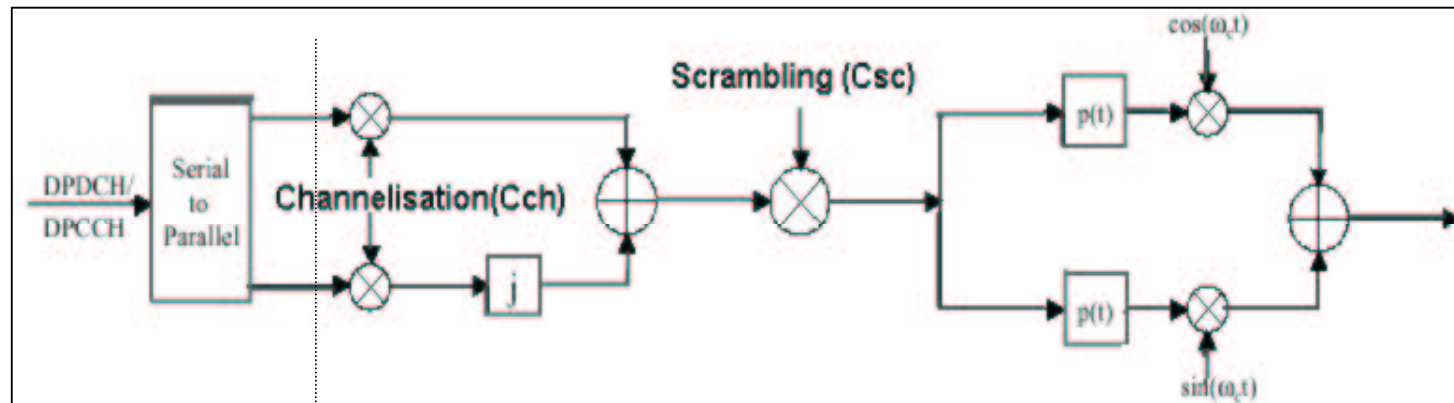

Bit rate \Rightarrow \Rightarrow Chip rate



Simulation model (IV): OVVSF and Gold code

OVVSF Code

- Purpose: Spreading
- Generation: Code tree

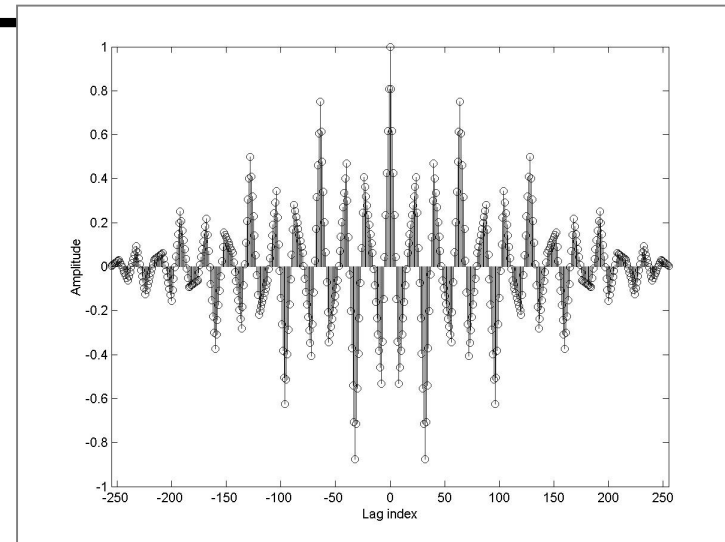
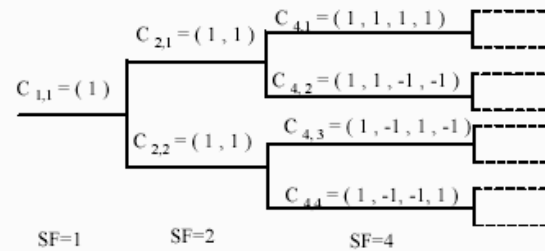

Gold Code

- Purpose: Scrambling
- Generation: modulo-2 sum m-sequences

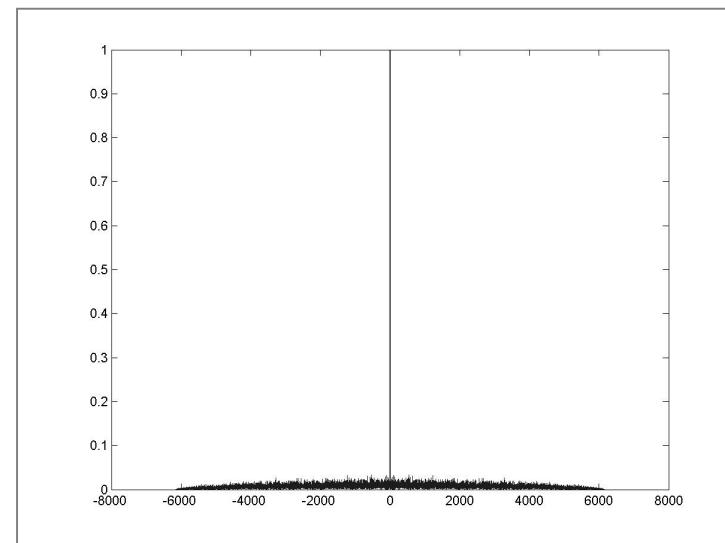

Simulation Model (V): Multipath Channel

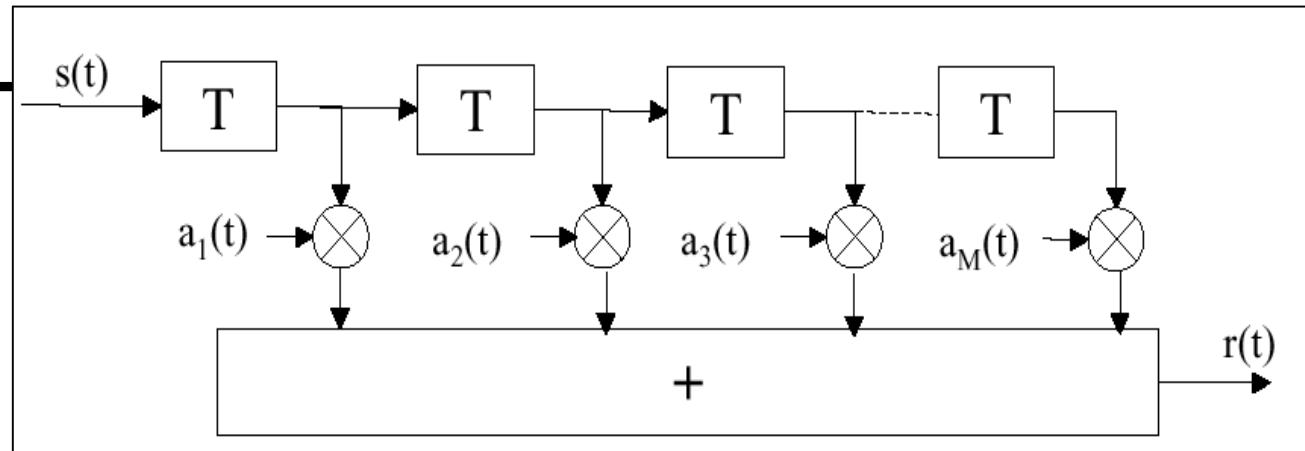

- Channel model from ITU recommendation :

– Indoor Channel A

Tap	1	2	3	4	5	6
Delay (ns)	0	50	110	170	290	310
Avg.Power (dB)	0	-3	-10	-18	-26	-32

– Outdoor to Indoor and Pedestrian Channel A

Tap	1	2	3	4
Delay (ns)	0	110	190	410
Avg.Power (dB)	0	-9.7	-19.2	-22.8

– Vehicular Channel A

Tap	1	2	3	4	5	6
Delay (ns)	0	310	710	1090	1730	2510
Avg.Power (dB)	0	-1	-9	-10	-15	-20

Simulation Model (VI): Rake Receiver

- Combine signals from multipath arrivals
- Signals are de-spread and de-scrambled in each finger.
- Weight signals to their SNR and coherence in phase.
Smaller signal mean worse SNR
- Maximal ratio, branches summed and weighted depending on their quality

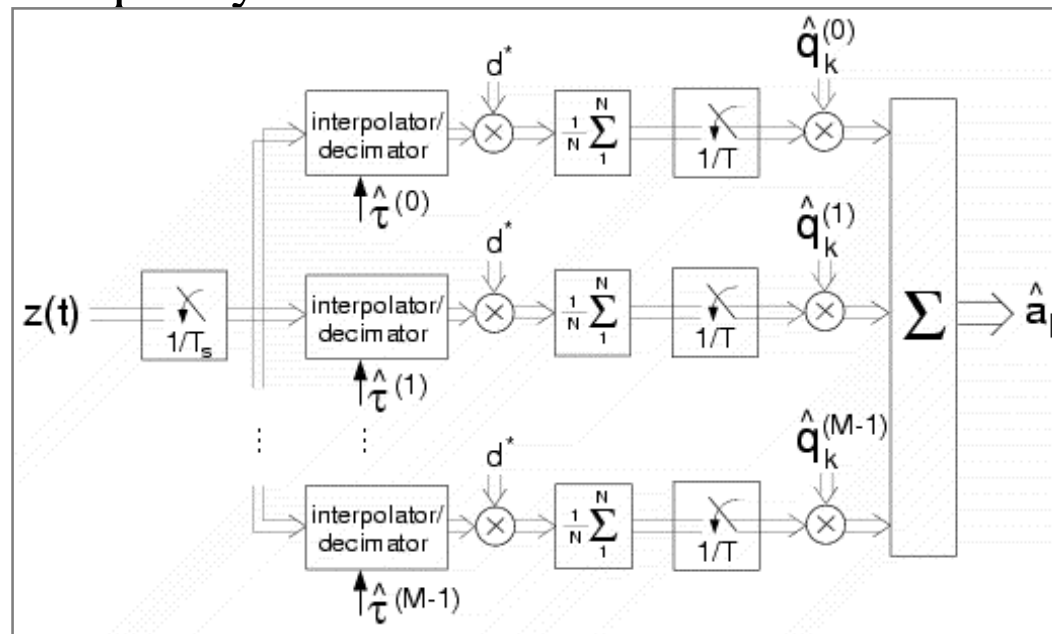



Simulation Results (I)

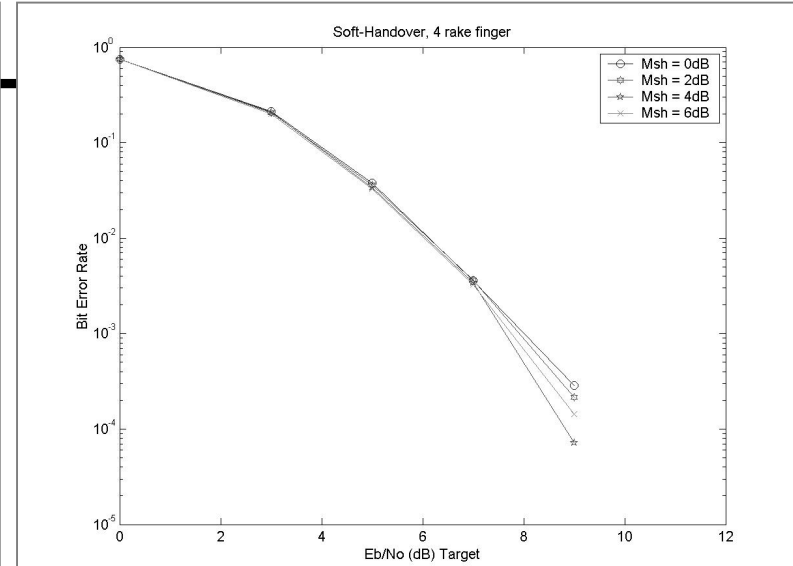
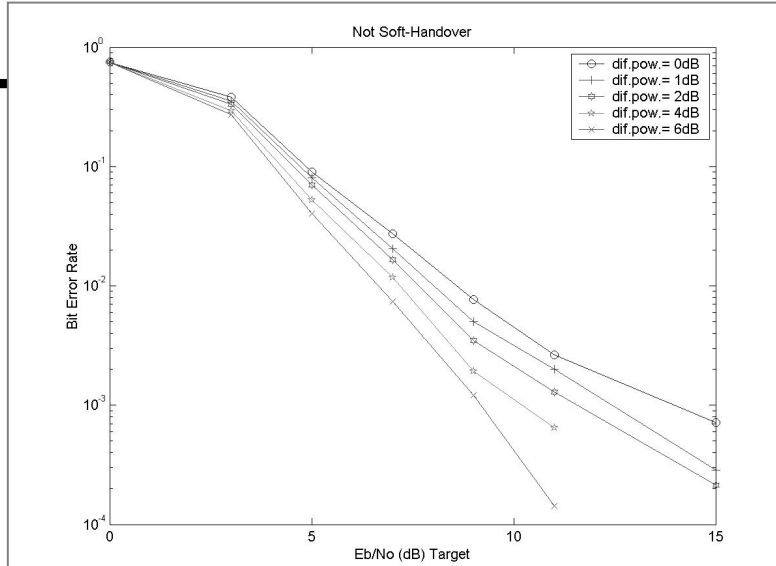

Vehicular environment, 4 taps, $f_d = 92.6$ Hz, SF = 256 (speech half rate), 15 users/cell

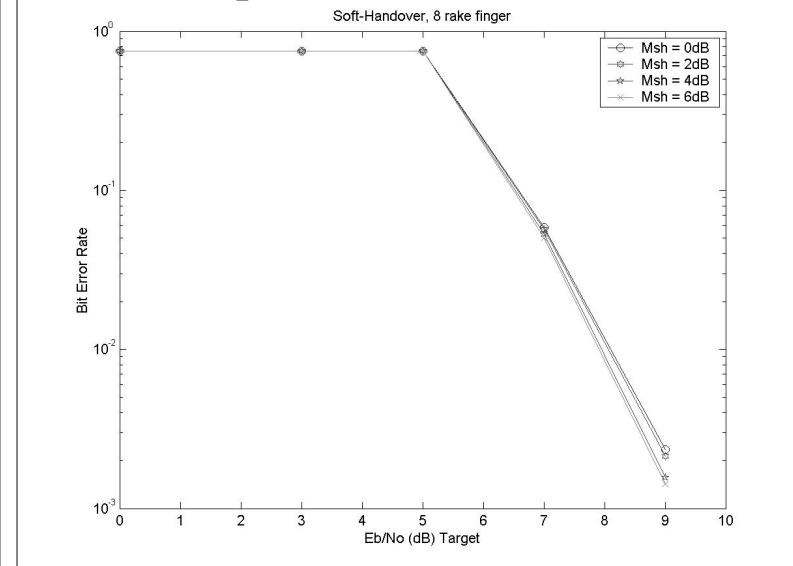
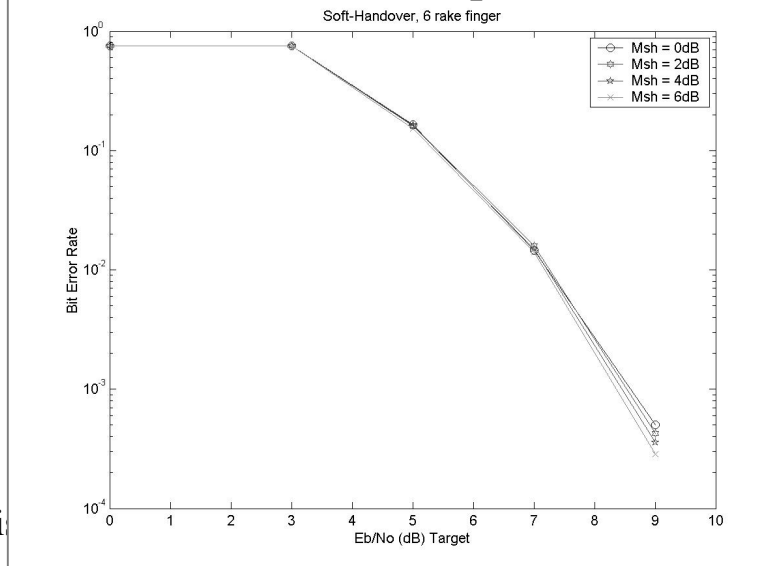

Simulation Results (II)



- Transmitted power ($M_{sh} = 6$ dB)

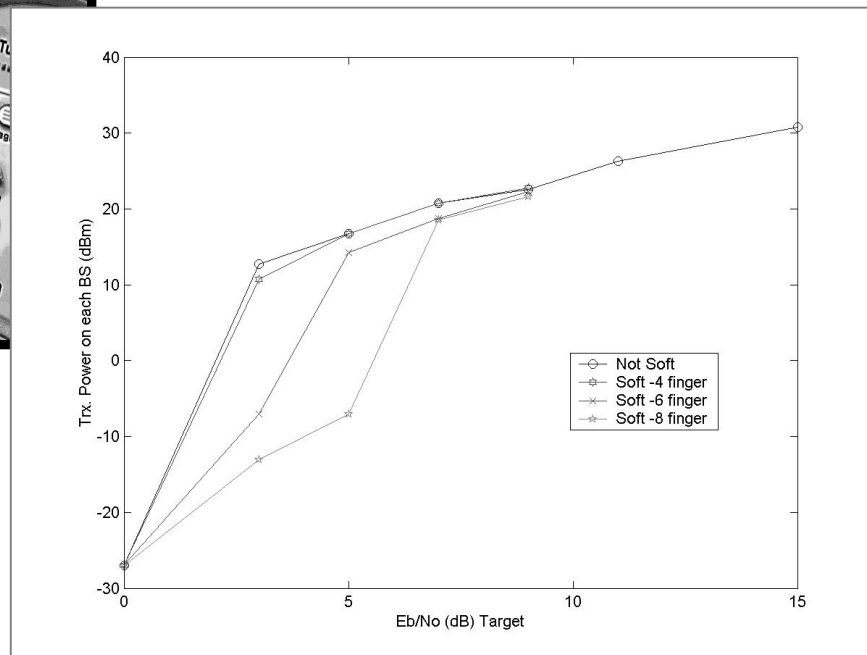

- Soft handover gain

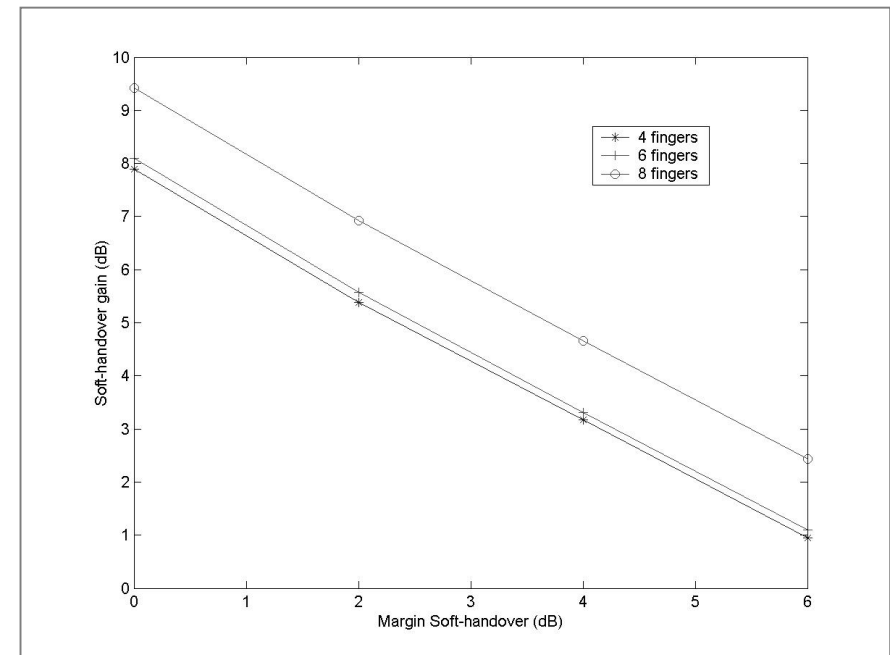

Vehicular environment, 4 taps, $f_d = 92.6$ Hz, SF = 256 (speech half rate), 15 users/cell

- The higher number of rake fingers, the lower transmitted power
- The higher number of rake fingers, the higher SHO gain

With more rake fingers you can collect more energy if there is high multipath diversity

Simulation Results (III)

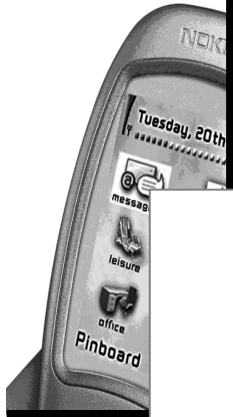

- Few users per cell, comparative between 5 and 15 users per cell

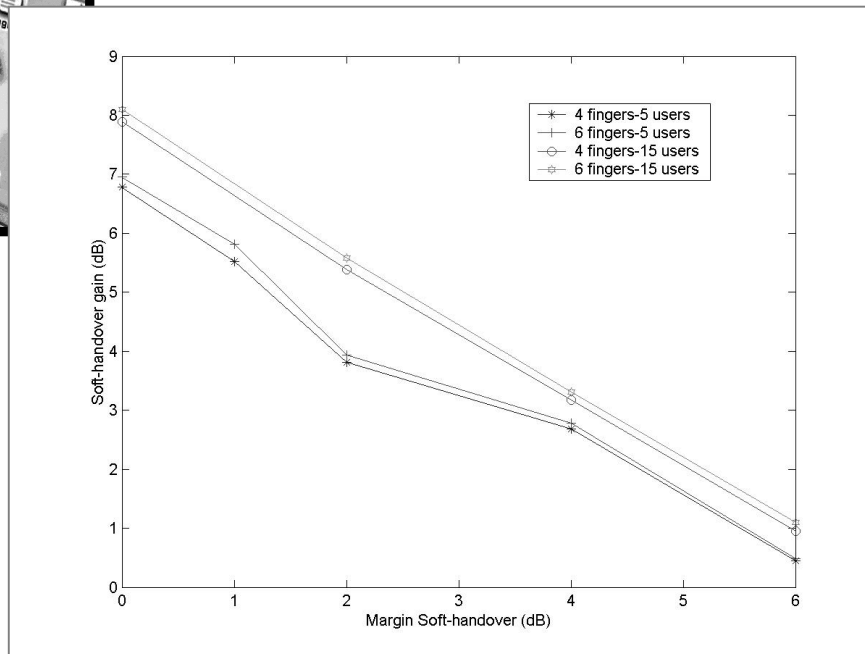

- The SHO gain is higher with more users per cell.

- Few multipath diversity, comparative between 2 and 4 taps per channel

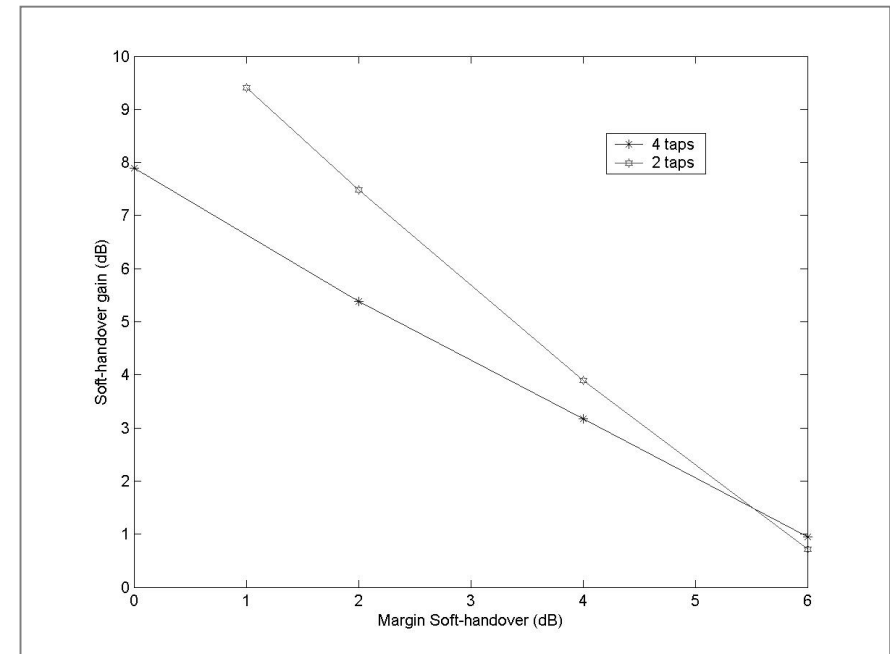

- The SHO gain is higher with few multipath diversity.



Simulation results (IV)

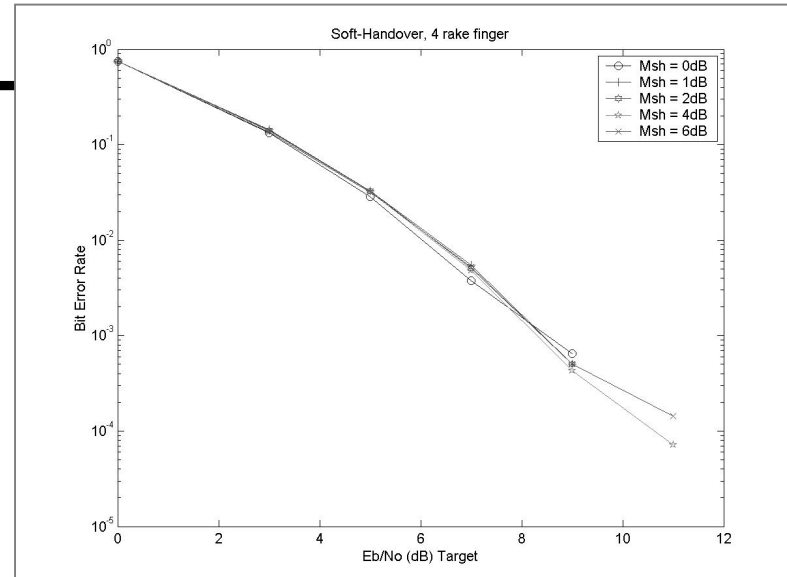
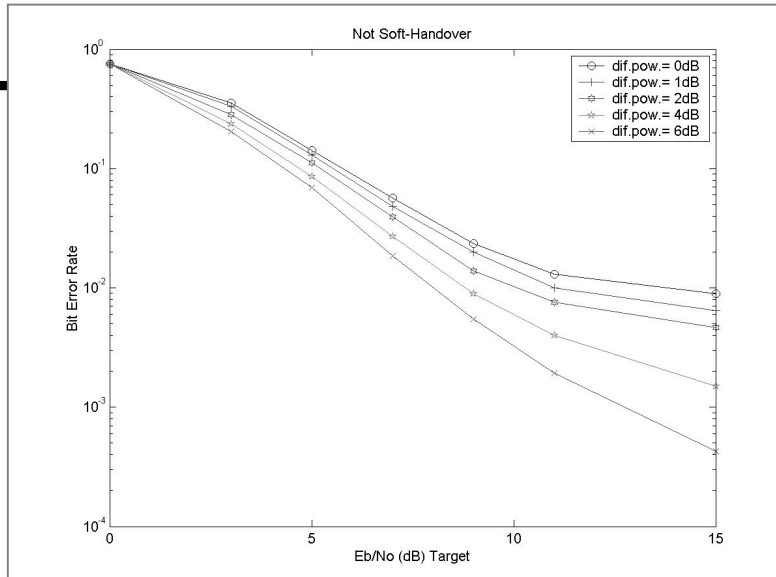

Pedestrian environment, 4 taps, $f_d = 15$ Hz, SF = 256 (speech half rate), 15 users/cell

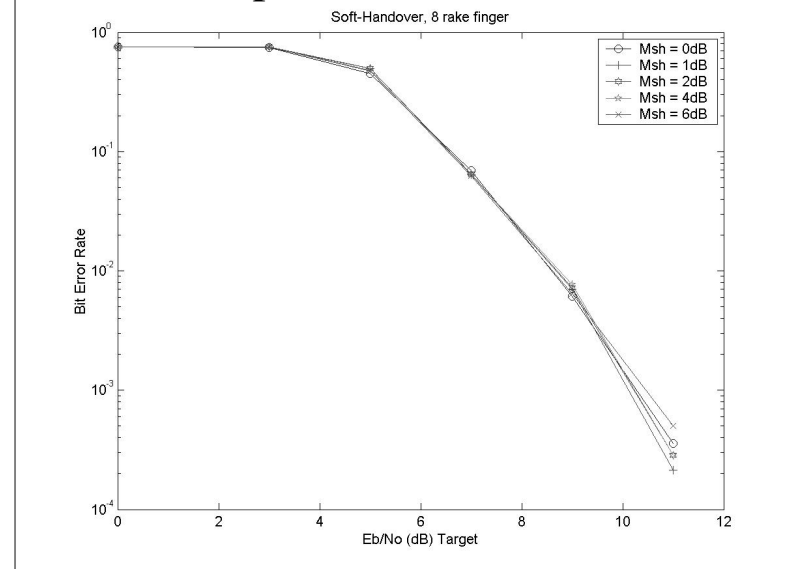
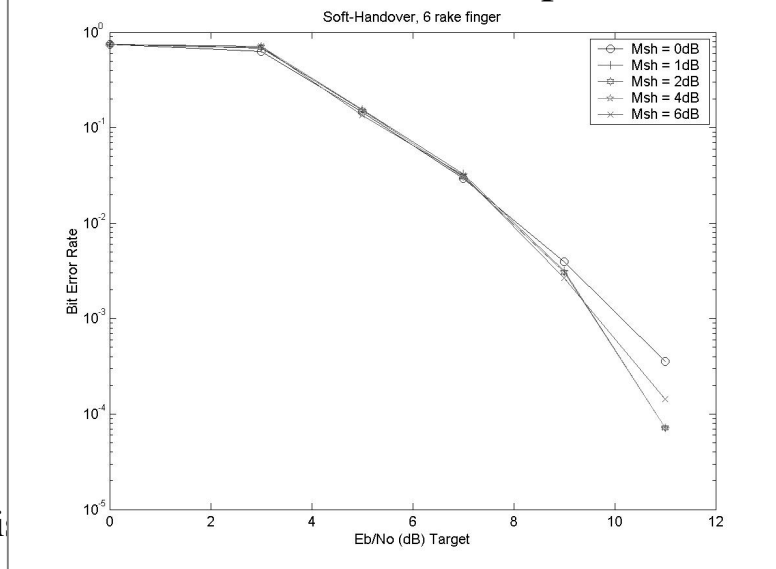

Simulation results (V)

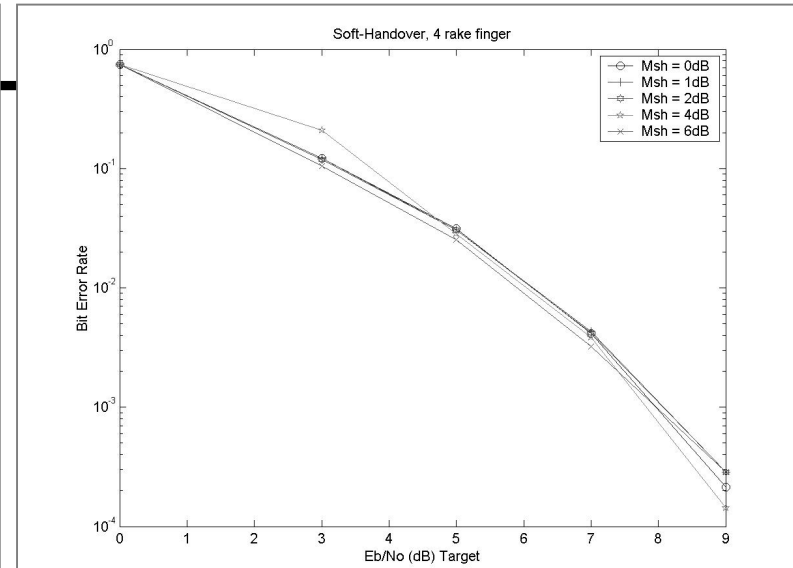
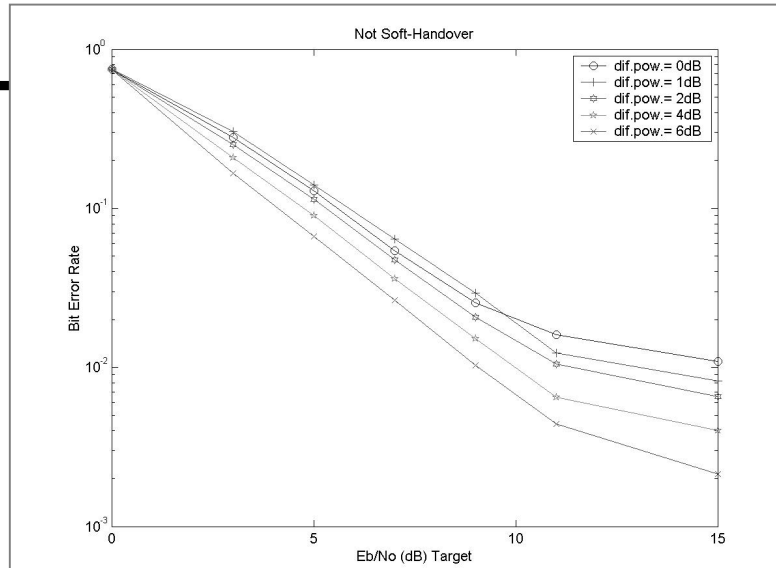

Indoor environment, 4 taps, $f_d = 15$ Hz, SF = 256 (speech half rate), 15 users/cell

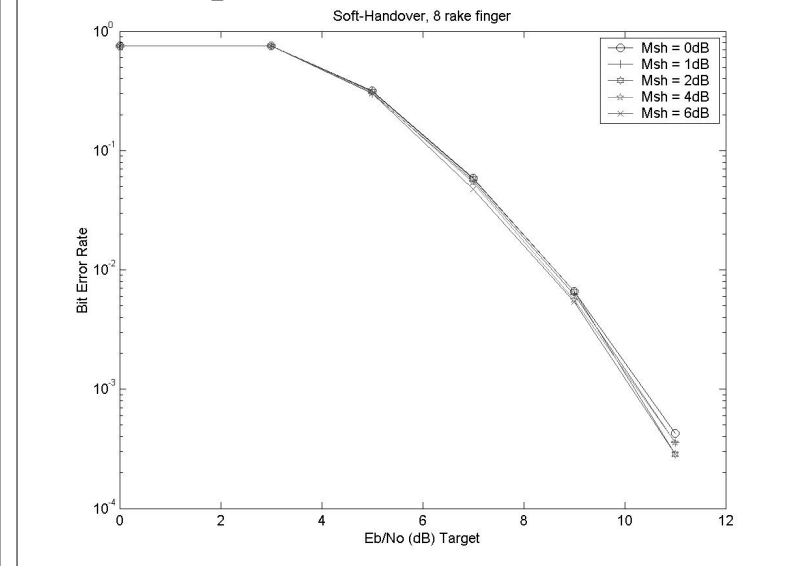
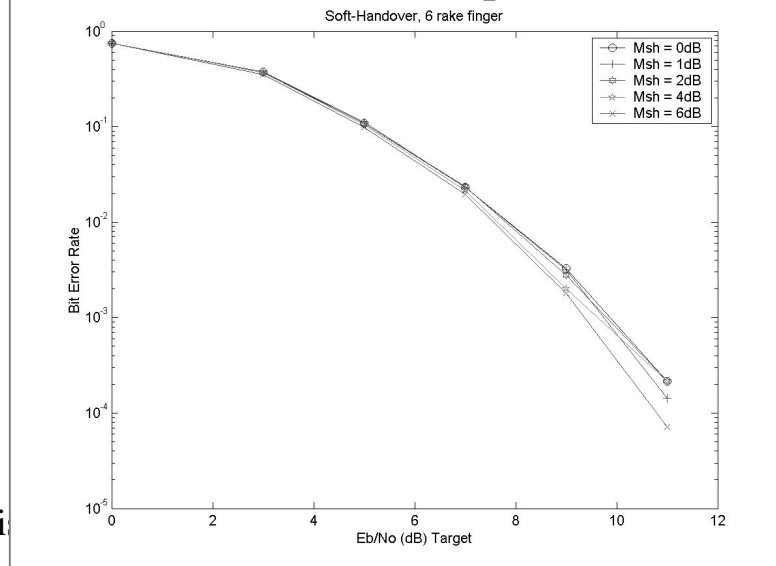



Conclusions



- The BER and the soft handover gain were calculated for different environments, soft handover margins and rake fingers.
- The highest gain was obtained when $M_{sh} = 0$ dB
- The soft handover gain was higher for environments with low multipath diversity
- The gain was also higher in scenarios with more interfering users
- The higher number of fingers, the lower energy to transmit
- The BER curves and the soft handover gain obtained are examples. These values depend on the channel, distribution of users, mobile speed, receiver algorithms,...
- Limitations in the estimation of the channel were found as consequence of the done assumptions.



Future work



- To implement channel coding and inter-leaving
- To change the pulse sampling according to the specifications
- The Rake receiver can be considered no ideal.
- To use the pilot bits from the DPDCH for the estimation of the channel.
- To use antenna diversity.
- Integrate this link simulator in Netsim
- Migration from simulink \Rightarrow flexible software



References



- [1] C.Mehailescu, X.Lagrange, Ph. Godlewski. “Soft Handover Analysis in Downlink UMTS WCDMA System”. Proceedings of IEEE International Workshop on Mobile Multimedia Communications. San Diego, USA, pp. 279-285,1999.
- [2] Daniel Romero Corell, Lluís Ferran Bueno Pablo, “Optimización de la capacidad de sistemas WCDMA mediante técnicas de Soft Handover”, 2001 UPV

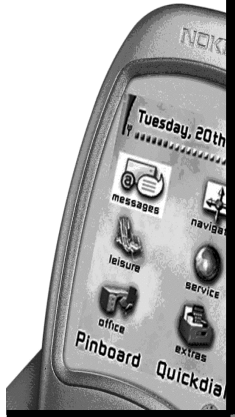

Questions?

CDMA systems

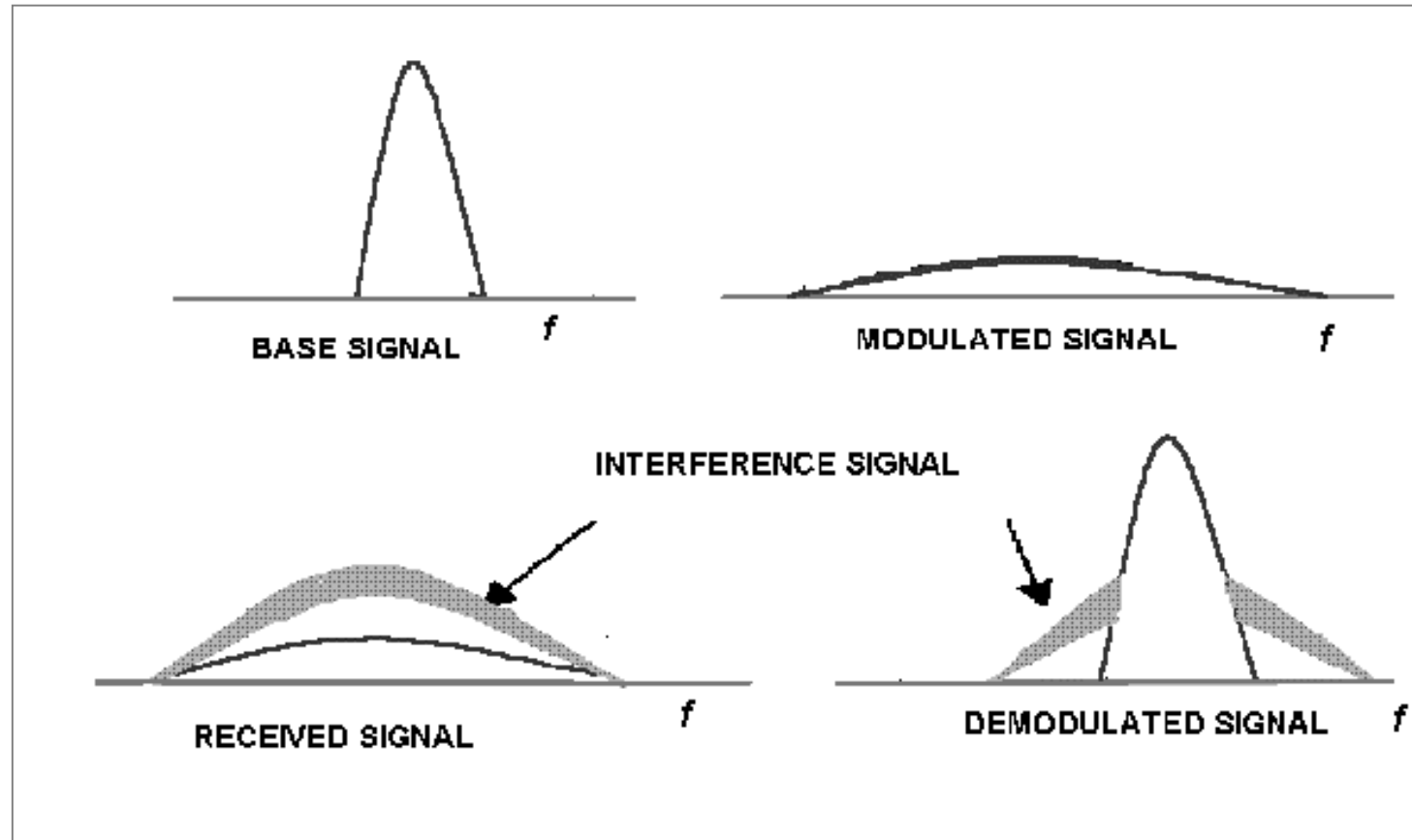



WCDMA Key Technical Characteristics



Multiple Access Scheme	DS-CDMA
Duplexing method	FDD/TDD
Packet Access	Dual mode (Combined and dedicated channel)
Chip Rate	3.84 Mcps
Carrier Spacing	4.4-5.2 MHz (200 kHz carrier raster)
Frame Length	10 ms
Service Multiplexing	Multiple services with different quality of service requirements multiplexed on one connection.
Multirate/ Variable rate scheme	Variable spreading factor and multi-code
Detection	Coherent using pilot symbols or common pilot

Capacity



- ***E_b/N_o is an important parameter of the link quality:***

$$\left(\frac{E_b}{N_o} \right) = \frac{W}{R_j} * \frac{P_j}{I_{total} - P_j}$$

- ***Capacity limitations:***
- ***Phenomenon in the wave propagation :***
 - *Small-scale fading*
 - *Large-scale fading*
 - *Path Loss (Okumura-Hata, COST-Walfish-Ikegami,...)*
- ***Thermal noise***
- ***Loss of orthogonality as consequence of a multipath propagation***
- ***Interference*** is the main limiting factor in WCDMA system.
 - ***Intercell interference*** is the sum of the powers received from all base stations except the serving one.
 - ***Intracell interference*** is the total power received from the serving base station except the desired signals of the considerer user.



Capacity improvement



- Sectorization
- Power Control
- Discontinuous Transmission
- Diversity:
 - Antenna Diversity
 - Polarisation Diversity
 - Time Diversity
 - Multipath Diversity (Rake receiver)
 - Macro Diversity(Soft Handover)